

ROHDE & SCHWARZ

Make ideas real



R & S[®] ESSENTIALS

FUNDAMENTALS OF DC POWER SUPPLIES

Measurement and monitoring

Flyer | Version 02.00



REMOTE SENSING



Significant voltage drops can occur on the supply leads from a power supply to a DUT, especially with longer connection leads or in applications with high current consumption, so that the programmed voltage is not attained at the DUT input. Power supplies offering remote sensing, also known as four-wire sensing, are able to compensate for these voltage drops. To achieve this, the voltage actually present at the DUT is measured using a pair of sense lines in addition to the force lines. The measured value is used to regulate the power supply's output voltage so that the desired voltage is present at the DUT input. Depending on the model, the Rohde & Schwarz power supplies provide remote sensing for each output channel.

Functional diagram of sense lines on a DC power supply

Four-wire remote sensing compensates for voltage drops on the load leads.

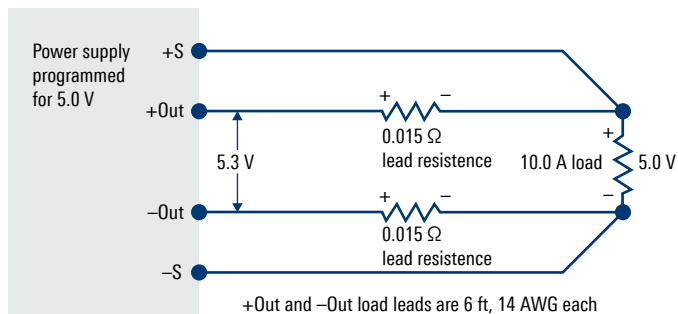

Backplane of an R&S®HMP4040 with force and sense connections.

Remote sensing	Front	Rear
R&S®HMC8041	•	•
R&S®HMC8042/8043		•
R&S®NGE100B		
R&S®NGA100		•
R&S®HMP2000/4000	•	•
R&S®NGP800	•	•
R&S®NGL201	•	•
R&S®NGL202		•
R&S®NGM201	•	•
R&S®NGM202		•
R&S®NGU201/401	•	•

BUILT-IN MEASUREMENTS



Rohde & Schwarz power supplies come with a range of built-in measurements that can in many applications replace additional instruments such as an external oscilloscope or a multimeter to measure e.g. instantaneous power. Since no extra load is connected to the power supply, no additional burden voltage needs to be taken into account – a major advantage offered by built-in measurements. In addition, they are very convenient and simplify the setup.

Advanced power supplies provide further analysis functions such as statistics, including min./max. and average values for power, voltage and current as well as an energy count.

High-precision power supplies such as the R&S®NGL200, R&S®NGM200 and R&S®NGU offer measurements with 6½ digit resolution. If in addition a power supply features a high-speed ADC, like with the R&S®NGM200 and R&S®NGU, even fast transients can be detected and measured.

Measured values can be recorded versus time using the logging functions (for details, see Logging on page 9). Some power supplies with a large display also offer graphical analysis functions (for details, see Graphical View on page 5).



Integrated statistics show the min./max. and average values for power, voltage and current as well as an energy count.

DIGITAL VOLTMETER FUNCTIONALITY



Some power supplies can be equipped with an optional integrated digital voltmeter (DVM), which even further expands the instruments' built-in measurement capabilities. The DVM allows measuring the voltage at any desired point in the DUT circuitry. This renders an additional multi-meter superfluous.

The DVM option is available for all R&S®NGM200 models and the R&S®NGU201.

Built-in digital voltmeter

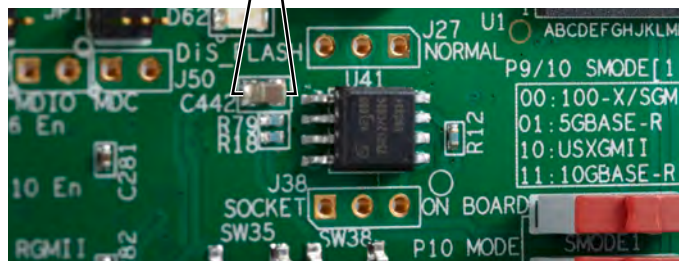
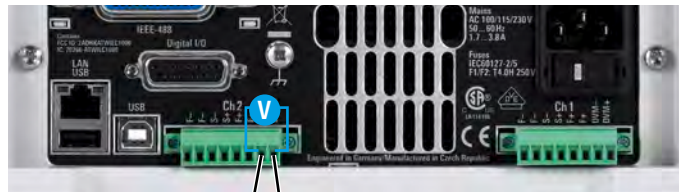

Measures the voltage at any point in the DUT circuitry.



DVM display on an R&S®NGM200 power supply.

GRAPHICAL VIEW



Analyzing and visualizing measurements in real time often requires an additional oscilloscope. There are only a few advanced power supplies with a high-resolution display that can offer basic oscilloscope functionality, exploiting their internal logging functionality in combination with their measurement capabilities. This feature is also available on some Rohde & Schwarz power supplies, where it is referred to as Graphical View. It enables quick and convenient analysis, especially of ongoing processes like the charging and discharging of batteries and the transitions between different operating states of a DUT. The integration of all measurements in one box reduces test setup complexity and ensures, by design, the integrity and correlation of all measurements.

Up to four traces can be displayed simultaneously in a single window on the instrument's front panel. Specific traces can be selected to display voltage, current and power for the individual channels, and the traces can be set to display the minimum and maximum values.

The values obtained for the selected quantities and channels are plotted versus time on the x-axis. The time base is always 5 s/div with a period of 60 s visible in roll mode.

The instrument automatically selects the optimal scaling for the data to be displayed.

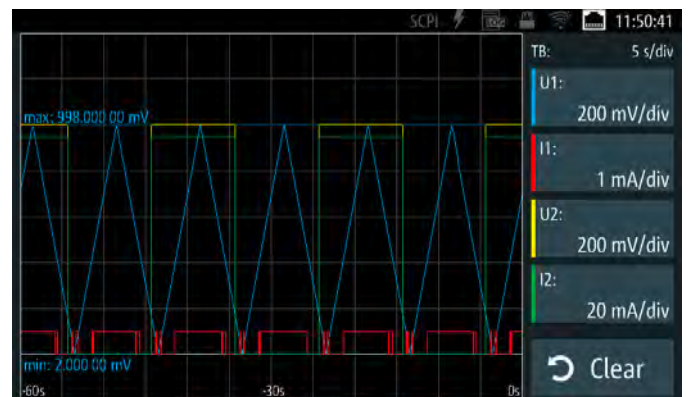

Graphical View on an R&S®NGP800.

	Graphical View available
R&S®HMC804x	–
R&S®NGE100B	–
R&S®NGA100	–
R&S®HMP2000/4000	–
R&S®NGP800	•
R&S®NGL200	•
R&S®NGM200	•
R&S®NGU201/401	•

ACCURACY AND RESOLUTION



Accuracy and resolution are often used synonymously, but they are two different things. Resolution is the smallest possible increment a measuring instrument is able to capture and display for a given measured quantity. Accuracy indicates how far a measured result deviates from the correct value. High resolution does not necessarily mean high accuracy and vice versa. Some measurements require high resolution and low accuracy, for example when making relative measurements. High accuracy is required when absolute measurement values are of interest.

In the example on the right, the measured current is 5 A. The ammeter has an accuracy of ± 0.4 A, meaning that the measured value can be up to 0.4 A above or below the correct value.

The lower ammeter has a tighter scaling for the readings, which means a higher resolution. Higher resolution reduces rounding errors, but has no influence on a device's accuracy.

Accuracy versus resolution

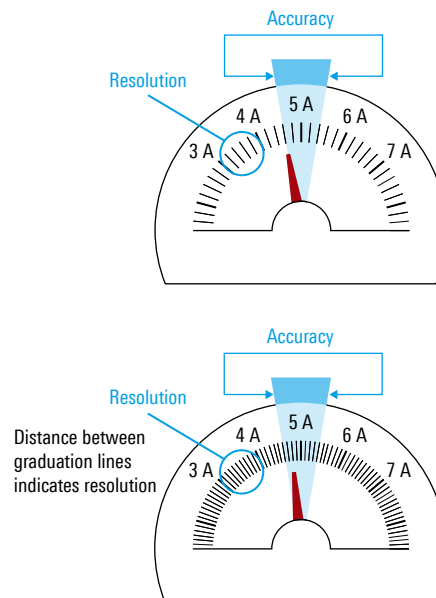

RESOLUTION

In general terms, resolution is the smallest discernable increment of a physical quantity. In mixed analog/digital systems, it mainly depends on the digital resolution, e.g. the number of digits in numerical representation.

There are two types of resolution in power supplies:

- ▶ Programming resolution: defines the granularity with which unloaded voltage and current limits can be set
- ▶ Readback resolution: defines the granularity with which the actual voltage and current can be measured

Programming resolution is the smallest selectable increment when setting voltage or current on a power supply. The resolution specification also indicates the number of discrete levels that can be set. The power supply's control loop regulates the voltage so that the programmed value is achieved at the output. The specified resolution represents one single step on a DAC. For example, the voltage programming resolution of the R&S®NGM200 series is 1 mV. This means that the value at the output can be changed in 1 mV steps. Power supplies of the R&S®NGM200 series, therefore, can be set to 0.999 V, 1 V, 1.001 V, etc.

The Rohde&Schwarz power supplies differ in their programming and readback resolutions. The table below shows the programming and readback resolution for voltage and current in the most sensitive range.

	Programming resolution	Readback resolution
R&S®HMC8041	1 mV/0.5 mA	1 mV/0.5 mA
R&S®HMC8042/43	1 mV/0.1 mA	1 mV/0.1 mA
R&S®NGE100B	10 mV/1 mA	10 mV/1 mA
R&S®NGA100	1 mV/1 mA	1 mV/1 µA
R&S®HMP2000	1 mV/0.1 mA	1 mV/0.1 mA
R&S®HMP4000	1 mV/0.2 mA	1 mV/0.2 mA
R&S®NGP800	1 mV/0.5 mA	1 mV/0.5 mA
R&S®NGL200	1 mV/0.1 mA	10 µV/10 µA
R&S®NGM200	1 mV/0.1 mA	5 µV/10 nA
R&S®NGU201/401	50 µV/100 nA	1 µV/100 pA

ACCURACY

Generally speaking, accuracy defines how close any value is to the correct value. Measurement accuracy defines how far a measured result deviates from the correct value.

There are two types of accuracies for power supplies:

- ▶ Programming accuracy: refers to how close the voltage or current output is to the set or programmed value
- ▶ Readback accuracy: refers to how accurately a power supply can measure the actual output voltage or current

The processes of output value programming and readback measurement are implemented by two different systems – with a D/A converter and an A/D converter, respectively. The programming accuracy is determined by the accuracy of the D/A converter and the readback accuracy by the accuracy of the A/D converter. The converters will usually have different accuracies and resolutions.

The programming accuracy of a power supply is a measure of how close the actual output will be to the programmed value. The voltage programming accuracy of the R&S®NGM200 series is $\pm < 0.02\% + 3 \text{ mV}$. If the output voltage is set to 20 V, the actual output voltage can be up to 7 mV ($20 \times 0.02\% + 3 \text{ mV} = 7 \text{ mV}$) above or below the set voltage, i.e. the actual output voltage will be between 19.993 V and 20.007 V.

$$V_{out} \times \text{Quantization error in \%} + \text{offset in V} = \Delta V_{out}$$

The accuracy specification for power supplies includes an error term for the quantization error. It also includes many other factors such as DAC accuracy, DAC linearity, gain errors of the feedback loops, and temperature drift of components.

The Rohde&Schwarz power supplies differ in their programming and readback accuracies. The diagrams below show the readback accuracies for the individual instruments.

Voltage readback accuracy in optimal measurement range

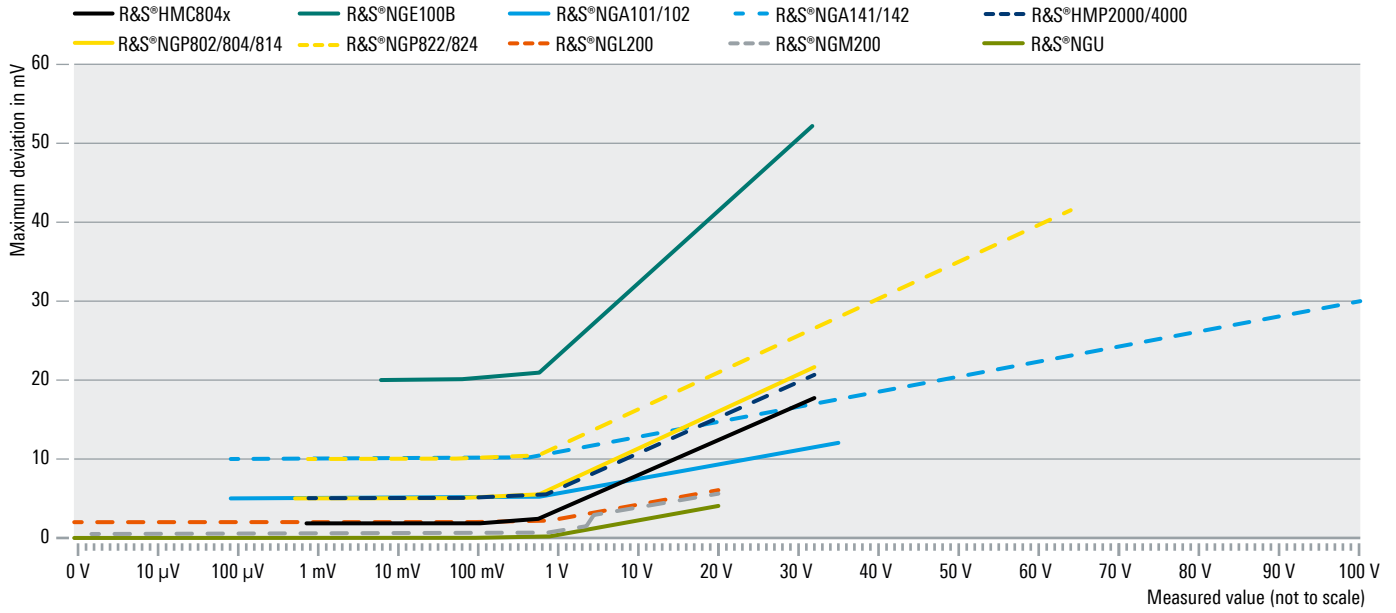

Current readback accuracy in optimal measurement range

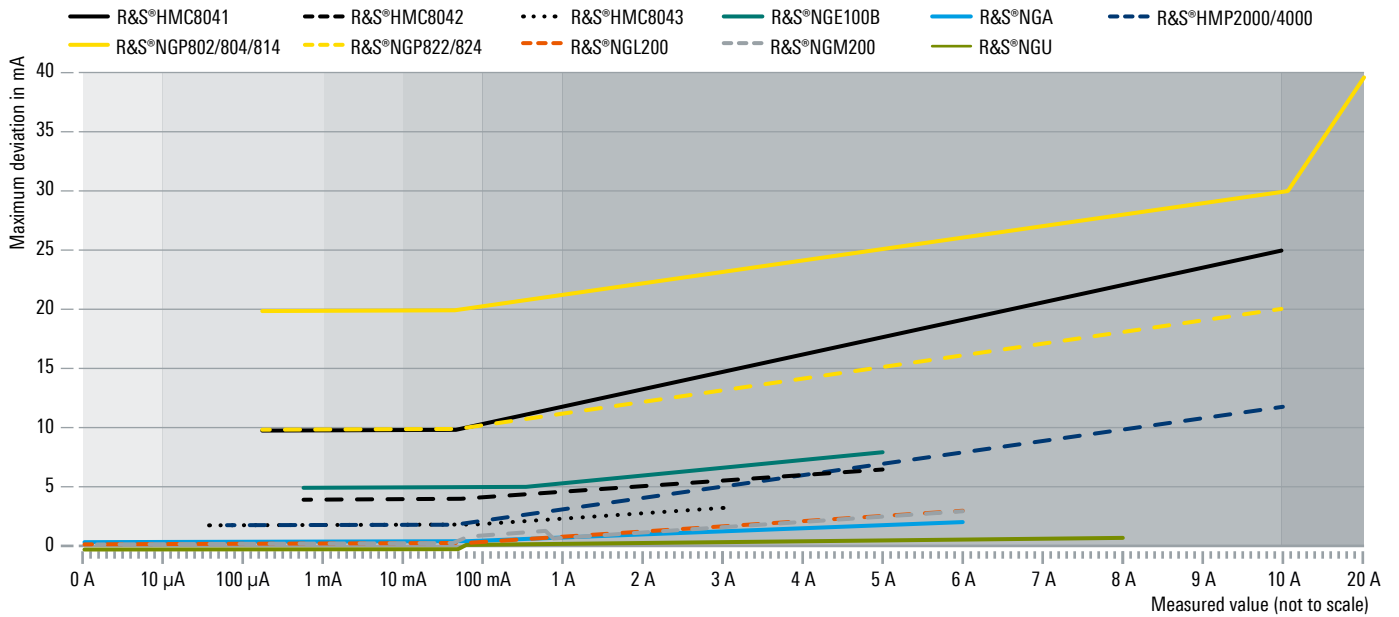

LOGGING



While measurement results provide a fast overview of the actual voltage, current and power measured on the DUT, it is in many applications desirable to monitor and view variations of these values, i.e. the DUT behavior, over long periods of time, or with high time resolution, or both.

STANDARD LOGGING AND FAST LOGGING

Most Rohde & Schwarz power supplies offer standard logging functionality, and some even feature fast logging functionality, with sample rates as shown in the table on the right.

Standard logging collects measurement data from all active channels of a power supply simultaneously and stores it to one common file. The settings for standard logging are therefore found in the power supply's Device menu.

The R&S®NGM200 and R&S®NGU power supplies additionally offer fast logging.

Fast logging (FastLog) with a sample rate up to 500 ksample/s allows capturing voltage and current values versus time in an oscilloscope-like manner. It can help analyze energy consumption of different functional blocks of a DUT and detect faults in the DUT's circuitry.

Fast logging collects measurement data from individual channels of a power supply and stores it to separate files. The settings for fast logging are therefore found in the Channel settings menus.

By logging the values of the current flowing through analog sensors like photo cells and thermistors, environmental data like illuminance and temperature can be determined.

	Standard logging	Fast logging
R&S®HMC804x	● 1000 sample/s	–
R&S®NGE100B	–	–
R&S®NGA100	● 10 sample/s	–
R&S®HMP2000/4000	–	–
R&S®NGP800	● 125 sample/s	–
R&S®NGL200	● 10 sample/s	–
R&S®NGM200	● 10 sample/s	● 500 ksample/s
R&S®NGU201/401	● 10 sample/s	● 500 ksample/s

DATA COLLECTION AND DATA STORAGE

For the user's convenience, logged data is written to ASCII files with character-separated values (*.csv). These files can be opened in an editor or in a spreadsheet.

Due to the large amount of data expected with fast logging, the power supply delivers this data in IEEE floating point format. The data can be stored to an external USB memory device or provided to a remote control host over an Ethernet or USB connection. Fast logs stored on an external memory device can be converted to *.csv format at a later date.

DATA VISUALIZATION

Since ASCII files in *.csv format can be opened in a spreadsheet, it is easy to quickly create diagrams of the captured data, e.g. using a scatter graph template.

An even more convenient alternative is using an application program like the 1GP122 logging tool from Rohde&Schwarz. It can be downloaded free of charge from the Rohde&Schwarz website.

STARTING STANDARD/FAST LOGGING

Standard or fast logging can be started manually, by remote control, by activating a power supply channel, or by an external event signalled at the digital trigger input. The trigger function allows the power consumption of connected loads to be captured even in the case of arbitrarily occurring events. It is also possible to synchronize the start of the logging with actions taking place on other measuring equipment.

FastLog high-speed acquisition

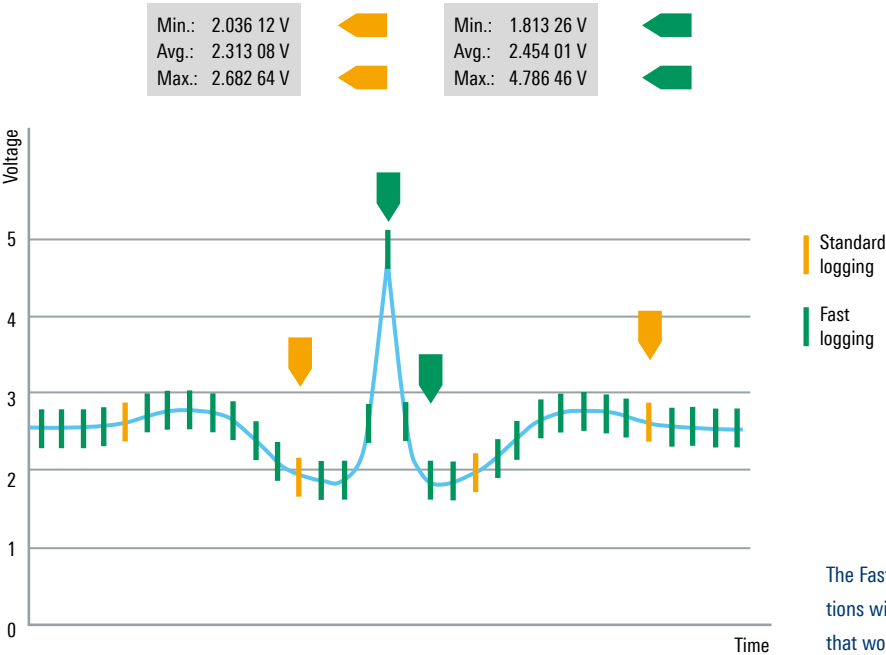

PRECISION MADE EASY



R&S® ESSENTIALS

Developers and engineers worldwide have been relying on the T&M expertise of Rohde & Schwarz for more than 80 years. The company is known for providing innovative performance testing solutions and applies its expertise and high quality standards to its portfolio of essential bench instruments – the R&S® Essentials. Rohde & Schwarz is building this industry-defining portfolio, ranging from oscilloscopes, DC power supplies and signal generators to spectrum analyzers, vector network analyzers, meters and counters with the strategic goal of becoming a full portfolio supplier in the T&M market. For R&S® Essentials, Rohde & Schwarz is extending its reach through a distribution network with channel partners worldwide, offering a one-stop shop experience for any type of T&M task, application and budget. Whether in the lab or field, on campus or in a production facility, R&S® Essentials demonstrate that high-quality hardware and software solutions do not have to come with a high price tag.

Service that adds value

- ▶ Worldwide
- ▶ Local and personalized
- ▶ Customized and flexible
- ▶ Uncompromising quality
- ▶ Long-term dependability

Rohde & Schwarz

The Rohde&Schwarz technology group is among the trail-blazers when it comes to paving the way for a safer and connected world with its leading solutions in test & measurement, technology systems and networks&cybersecurity. Founded more than 85 years ago, the group is a reliable partner for industry and government customers around the globe. The independent company is headquartered in Munich, Germany and has an extensive sales and service network with locations in more than 70 countries. www.rohde-schwarz.com

Sustainable product design

- ▶ Environmental compatibility and eco-footprint
- ▶ Energy efficiency and low emissions
- ▶ Longevity and optimized total cost of ownership

Certified Quality Management

ISO 9001

Certified Environmental Management

ISO 14001

Rohde & Schwarz training

www.training.rohde-schwarz.com

Rohde & Schwarz customer support

www.rohde-schwarz.com/support

